

SIP SERIES

HD351

SIP Cordless 1-line Hotel Telephone

HD351W

SIP Cordless 1-line Wi-Fi Enabled Hotel Telephone

HD3

SIP Cordless 1-line Handset and Charger

snom

User Manual

IMPORTANT SAFETY INSTRUCTIONS

The applied nameplate is located at the bottom or rear of the product.

When using your telephone equipment, basic safety precautions should always be followed to reduce the risk of fire, electric shock and injury, including the following:

1. This product should be installed by a qualified technician.
2. This product should only be connected to the host equipment and never directly to the network such as Public Switch Telephone Network (PSTN) or Plain Old Telephone Services (POTS).
3. Read and understand all instructions.
4. Follow all warnings and instructions marked on the product.
5. Unplug this product from the wall outlet before cleaning. Do not use liquid or aerosol cleaners. Use a damp cloth for cleaning.
6. Do not use this product near water such as near a bath tub, wash bowl, kitchen sink, laundry tub or swimming pool, or in a wet basement or shower.
7. Do not place this product on an unstable table, shelf, stand or other unstable surfaces.
8. Slots and openings in the back or bottom of the telephone base and handset are provided for ventilation. To protect them from overheating, these openings must not be blocked by placing the product on a soft surface such as a bed, sofa or rug. This product should never be placed near or over a radiator or heat register. This product should not be placed in any area where proper ventilation is not provided.
9. This product should be operated only from the type of power source indicated on the marking label. If you are not sure of the type of power supply on the premises, consult your dealer or local power company.
10. Do not allow anything to rest on the power cord. Do not install this product where the cord may be walked on.
11. Never push objects of any kind into this product through the slots in the telephone base or handset because they may touch dangerous voltage points or create a short circuit. Never spill liquid of any kind on the product.
12. To reduce the risk of electric shock, do not disassemble this product, but take it to an authorised service facility. Opening or removing parts of the telephone base or handset other than specified access doors may expose you to dangerous voltages or other risks. Incorrect reassembling can cause electric shock when the product is subsequently used.
13. Do not overload wall outlets and extension cords.
14. Unplug this product from the wall outlet and refer servicing to an authorised service facility under the following conditions:
 - When the power supply cord or plug is damaged or frayed.
 - If liquid has been spilled onto the product.
 - If the product has been exposed to rain or water.
 - If the product does not operate normally by following the operating instructions. Adjust only those controls that are covered by the operation instructions. Improper adjustment of other controls may result in damage and often requires extensive work by an authorised technician to restore the product to normal operation.
 - If the product has been dropped and the telephone base and/or handset has been damaged.
 - If the product exhibits a distinct change in performance.

15. Avoid using a telephone (other than cordless) during an electrical storm. There is a remote risk of electric shock from lightning.
16. Do not use the telephone to report a gas leak in the vicinity of the leak. Under certain circumstances, a spark may be created when the adapter is plugged into the power outlet, or when the handset is replaced in its cradle. This is a common event associated with the closing of any electrical circuit. The user should not plug the telephone into a power outlet, and should not put a charged handset into the cradle, if the telephone is located in an environment containing concentrations of flammable or flame-supporting gases, unless there is adequate ventilation. A spark in such an environment could create a fire or explosion. Such environments might include: medical use of oxygen without adequate ventilation; industrial gases (cleaning solvents; petrol vapours; etc.); a leak of natural gas; etc.
17. Only put the handset of your telephone next to your ear when it is in normal talk mode.
18. The power adapters are intended to be correctly oriented in a vertical or floor mount position. The prongs are not designed to hold the plug in place if it is plugged into a ceiling, under-the-table or cabinet outlet.
19. Use only the power cord and batteries indicated in this manual. Do not dispose of batteries in a fire. They may explode. Check with local codes for possible special disposal instructions.
20. In wall mounting position, make sure to mount the telephone base on the wall by aligning the eyelets with the mounting studs of the wall plate. Then slide the telephone base down on both mounting studs until it locks into place. Refer to the full instructions in Installation in the user's manual.
21. This product should be mounted at a height of less than 2 meters.
22. Listed PoE (The product is considered not likely to require connection to an Ethernet

network with outside plant routing).

CAUTIONS

- Keep small metallic objects such as pins and staples away from the handset receiver;
- Risk of explosion if battery is replaced by incorrect type;
- Dispose of used batteries according to the instructions;
- Disconnect the telephone line before replacing batteries;
- For pluggable equipment, the socket-outlet (power adaptor) shall be installed near the equipment and shall be easily accessible;
- Avoid using the battery in the following conditions:-
 - High or low extreme temperatures that a battery can be subjected to during use, storage or transportation;
 - Low air pressure at high altitude;
 - Replacement of a battery with an incorrect type that can defeat a safeguard;
 - Disposal of a battery into fire or a hot oven, or mechanically crushing or cutting of a battery that can result in an explosion;
 - Leaving a battery in an extremely high temperature surrounding environment that can result in an explosion or the leakage of flammable liquid or gas;
 - Extremely low air pressure that can result in an explosion or the leakage of flammable liquid or gas.







SAVE THESE INSTRUCTIONS

TABLE OF CONTENTS

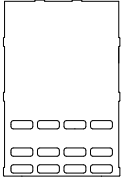
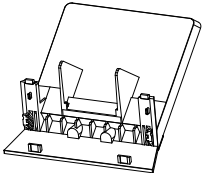
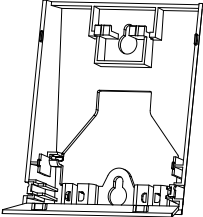
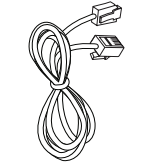
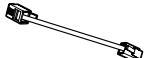
Important safety instructions.....	2
Parts check list.....	5
Telephone layout	7
Installation.....	10
Set up	16
Voice Menu	17
Operation.....	18
Appendix	20
Troubleshooting.....	20
Maintenance	26
Disclaimer and Limitation of Liability	26
European Directives	26
Declaration of Conformity	26
Disposal of batteries and product.....	27

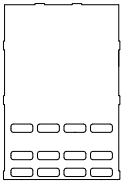
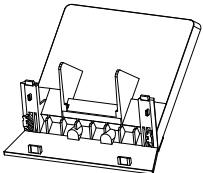
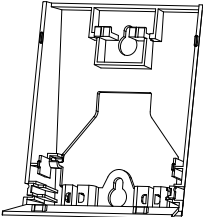
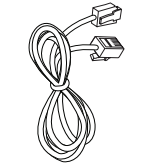
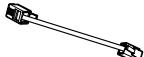
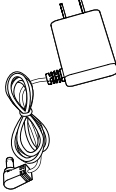
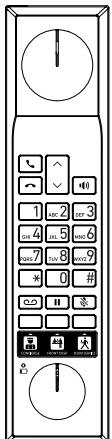

Parts check list

Items contained in the respective **cordless telephone** package:

MODEL NAME	MODEL NUMBER	PARTS INCLUDED				
		TELEPHONE BASE WITH OVERLAY	BASE STAND WALL MOUNT BRACKET	ETHERNET CABLE SHORT ETHERNET CABLE TELEPHONE BASE POWER ADAPTER	CORDLESS HANDSET AND HANDSET BATTERY	HANDSET CHARGING BASE POWER ADAPTER
SIP Cordless 1-line Hotel Telephone	HD351	 	 	 	 	
SIP Cordless 1-line Wi-Fi Enabled Hotel Telephone	HD351W	 	 	  	 	

Parts check list (continued)

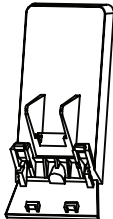
Items contained in the respective **cordless telephone** package:

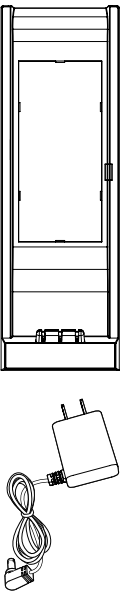
MODEL NAME	MODEL NUMBER	PARTS INCLUDED				
		TELEPHONE BASE WITH OVERLAY	BASE STAND WALL MOUNT BRACKET	ETHERNET CABLE SHORT ETHERNET CABLE TELEPHONE BASE POWER ADAPTER	CORDLESS HANDSET AND HANDSET BATTERY	HANDSET CHARGING BASE POWER ADAPTER
Cordless 1-line Handset and Charging Base	HD3					

Telephone layout

SIP Cordless 1-line Hotel Telephone - HD351

SIP Cordless 1-line Wi-Fi Enabled Hotel Telephone - HD351W

TELEPHONE BASE

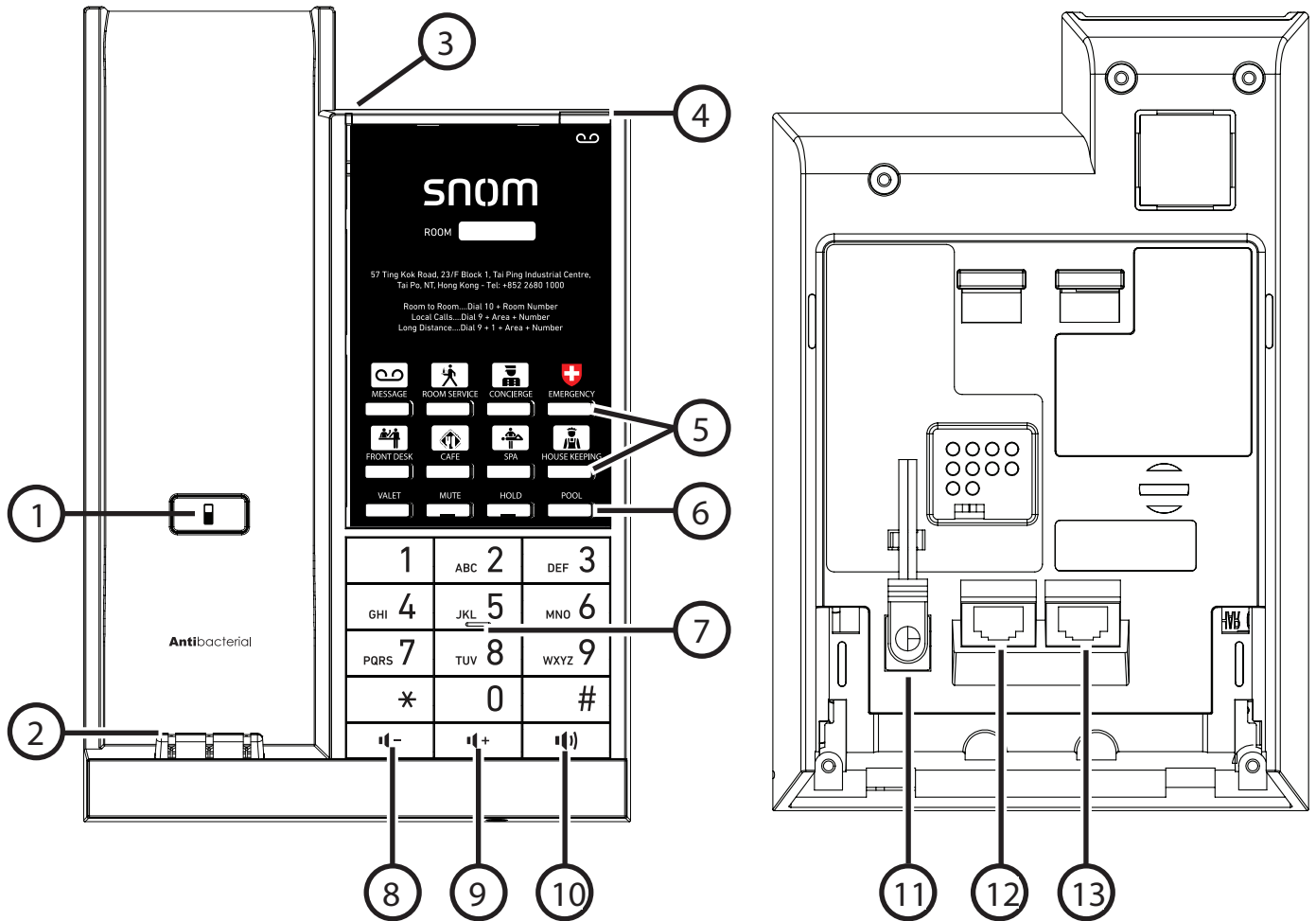

1	Find Handset button
2	Charging poles
3	Charge LED
4	Message waiting LED
5	Speed dial keys
	MESSAGE key
	MUTE key
	HOLD key
6	EMERGENCY key
7	Numeric dial keys
8	- VOLUME - key
9	+ VOLUME + key
10	SPEAKER key

11	Power adapter input
12	NET Ethernet port
13	PC Ethernet port

Telephone layout

SIP Cordless 1-line Hotel Telephone

SIP Cordless 1-line Wi-Fi Enabled Hotel Telephone - HD351W

HANDSET

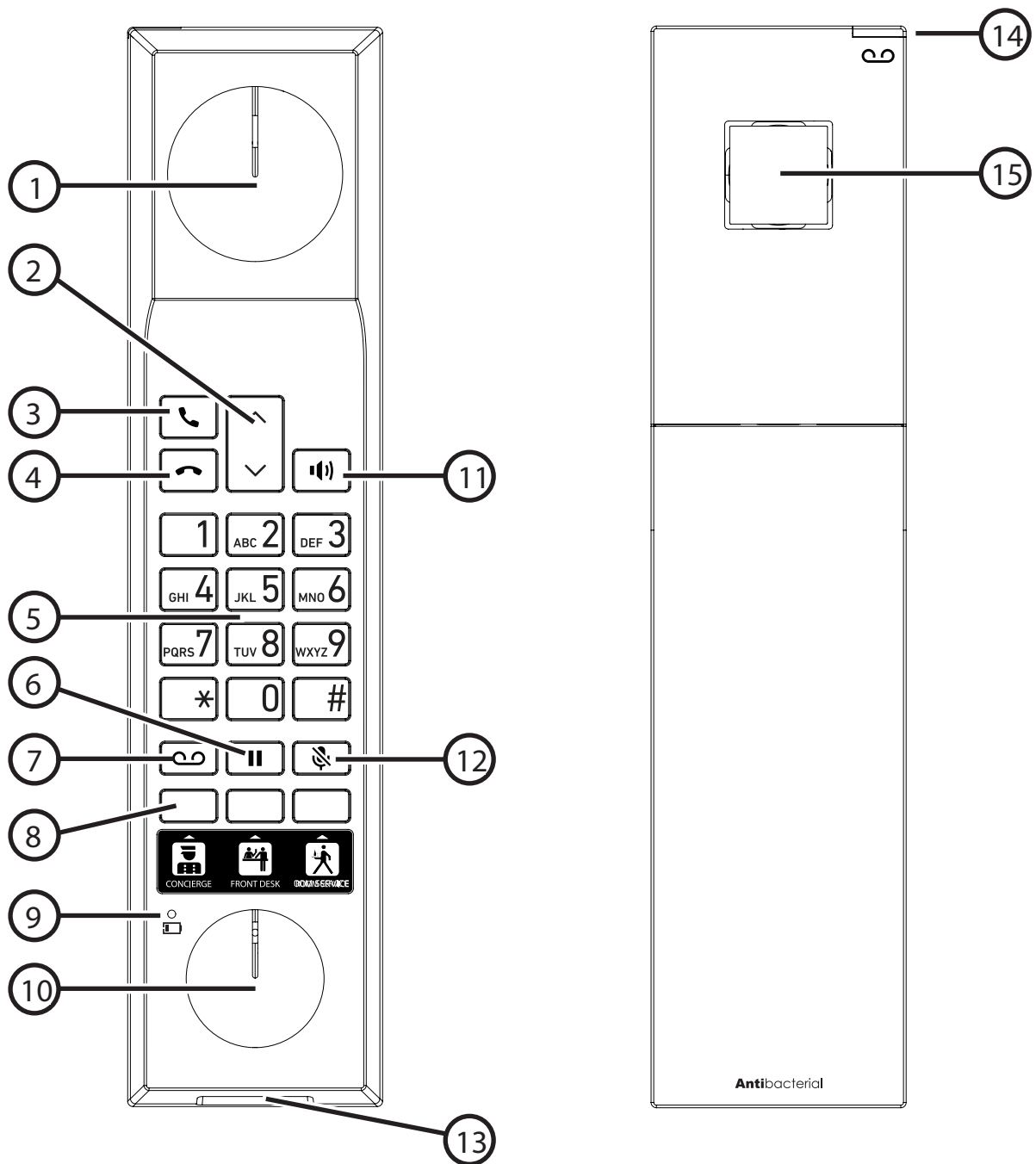

1	Handset earpiece
2	^ v VOLUME keys
3	☎ TALK/FLASH key
4	⏏ OFF/Cancel key
5	Numeric dial keys
6	HOLD key
7	📧 MESSAGES key
8	Speed dial keys

9	Low battery LED
10	Microphone
11	🔊 SPEAKER key
12	🔇 MUTE key
13	Charging contacts
14	Message waiting LED
15	Speakerphone

Cordless 1-line Handset Charging Base - HD3

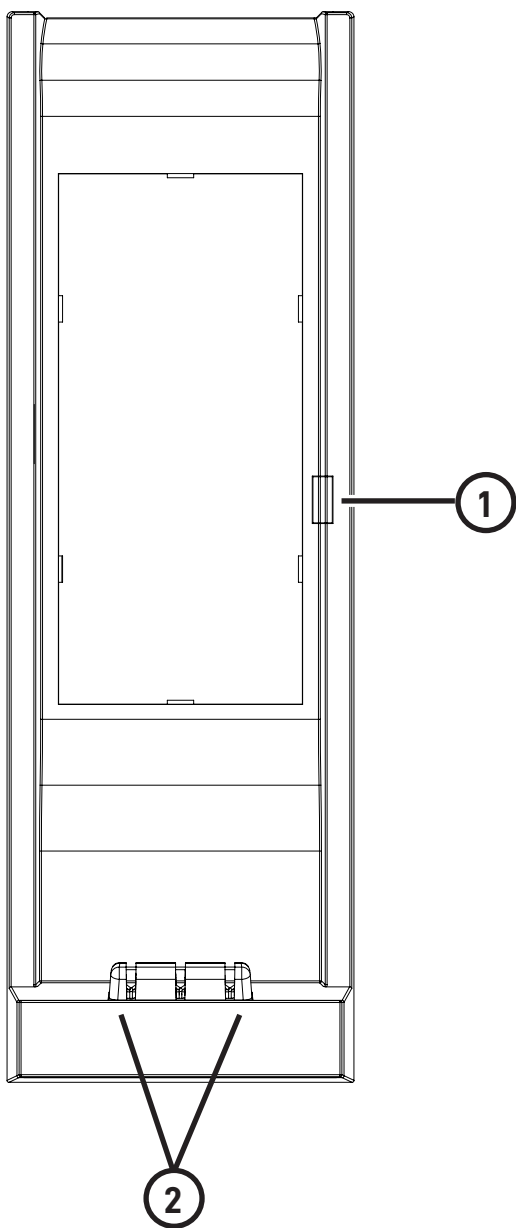

1	Charge LED
2	Charging poles

Installation

SIP Cordless 1-line Hotel Telephone - HD351

SIP Cordless 1-line Wi-Fi Enabled Hotel Telephone - HD351W

TELEPHONE BASE INSTALLATION

The telephone comes ready for desktop use.

1. Install the telephone base as shown below.

- NOTE: Power adapter is not required for Power over Ethernet (PoE).

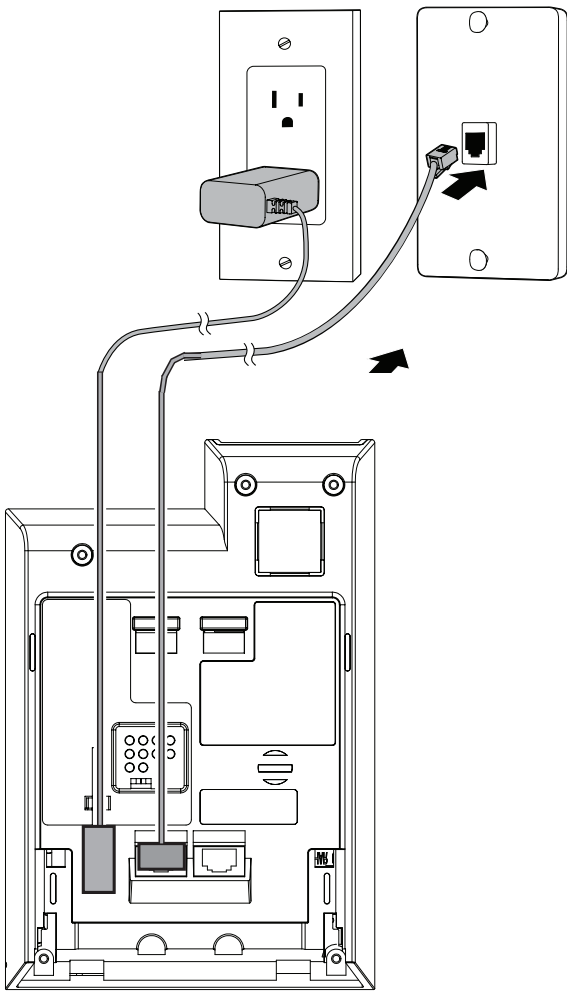

2. When the telephone base has been initially installed, make sure the power adapter is securely plugged into an outlet not controlled by a wall switch, and the Ethernet cable is plugged into the network wall jack.

- The battery is fully charged after 11 hours of continuous charging. For best performance, keep the cordless handset in the telephone base when not in use.

3. Press **⏏** on the telephone base. Listen for a dial tone, then press **⏏** again to hang up.

NOTE

- The dial tone will not be played if the SIP account used by this telephone cannot be registered.
- The power adapter is sold separately.
- Use only the power adapter described in "Technical specifications" on page 28.

CAUTIONS

Use only the supplied Ethernet cables. The supplied Ethernet cables are not designed for use in any other IT devices. Misusing them on your other IT devices shall be prohibited. To order a replacement, contact authorized service personnel, your seller, or Snom.

INSTALLATION OPTION - INSTALL BASE STAND FOR DESKTOP

TO MOUNT THE TELEPHONE BASE ON THE BASE STAND

1. Align the grooves of the base stand with the telephone base.
2. Slide the base stand up to secure it.

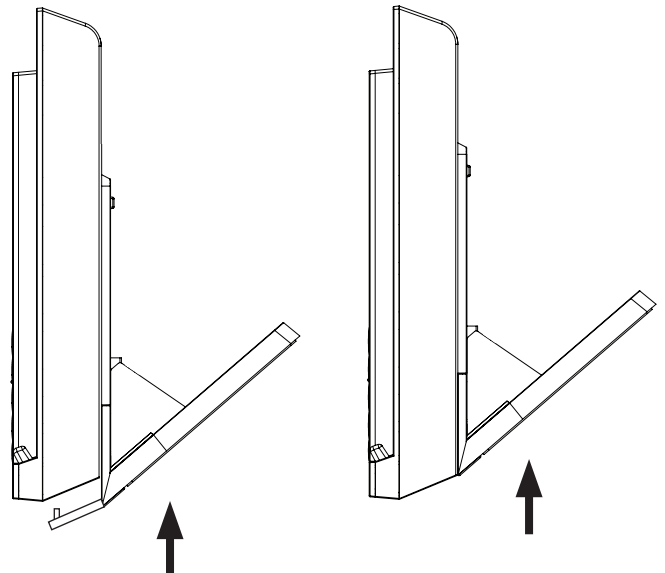

TO UNMOUNT THE BASE STAND

Simply slide the base stand down, and lift it from the telephone base.

INSTALLATION OPTION - CONVERTING FROM DESKTOP TO WALL MOUNT POSITION

TO MOUNT THE TELEPHONE BASE ON THE WALL

1. Unmount the base stand from the telephone base. Disconnect all cords and cables from the telephone base. Put the cordless handset aside.
2. Turn the telephone base over with the bottom side facing up.
3. Align the grooves with the wall mount bracket.
4. Slide the wall mount bracket up.

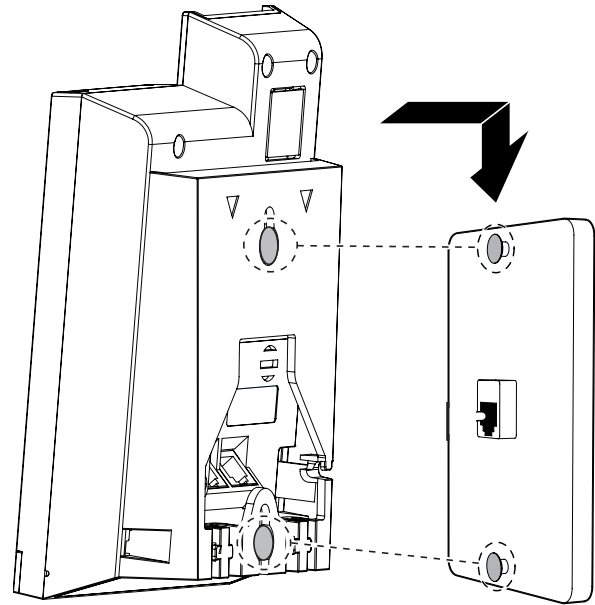
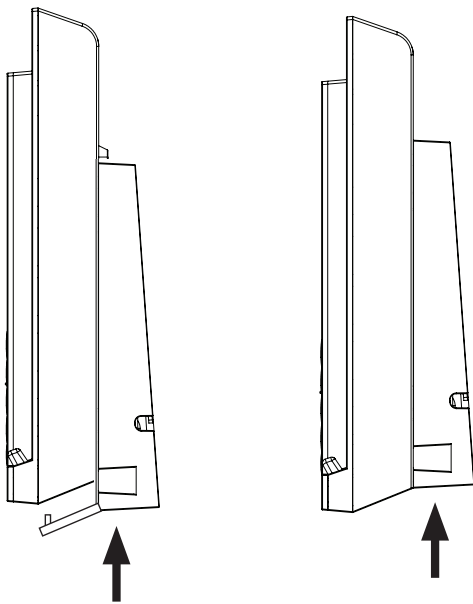

7. Replace the cordless handset on the telephone base cradle.

TO REMOVE THE WALL MOUNT BRACKET FROM THE TELEPHONE BASE

1. Slide the telephone base up to remove it from the mounting studs on the wall.
2. Disconnect all cords and cables from the telephone base.
3. Slide the wall mount bracket down and lift it from the telephone base.

5. Connect the telephone as described in "Telephone base installation" on page 10, but use the short Ethernet cable. The short Ethernet cable and power adapter cable stick out from the hole in the wall mount bracket.
6. Mount the telephone base on the wall by positioning the eyelets on the telephone base and the mounting bracket against the mounting studs. Then slide the telephone base down on both mounting studs until it locks into place.

WALL MOUNT BRACKET DIMENSIONS

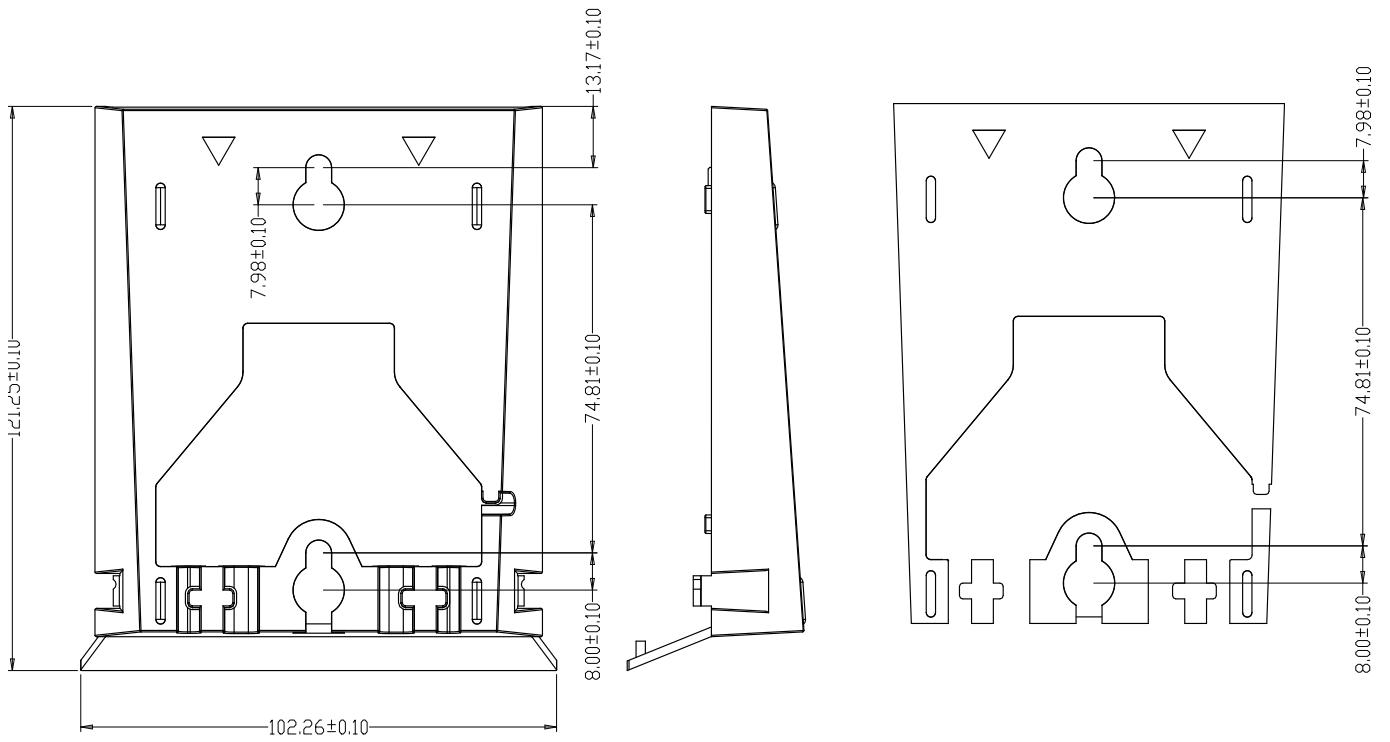

Unit: mm

INSTALLING OR REPLACING A CORDLESS HANDSET BATTERY

To install or replace the handset battery, follow the steps below.

1. Hold the handset.
2. Press both thumbs down on the edge of the battery cover near the speaker, and slide the battery cover downwards.

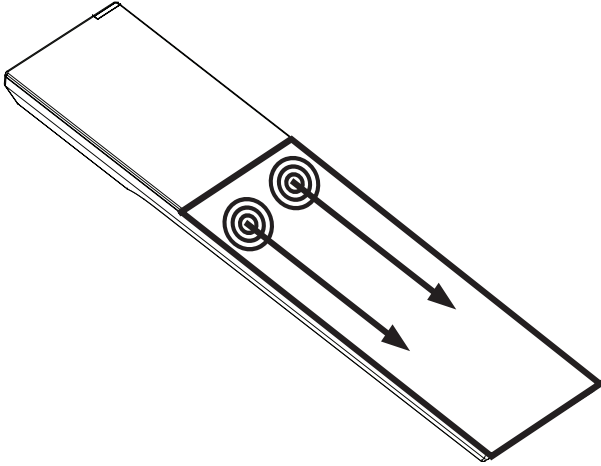

3. Lift the battery cover off the handset.

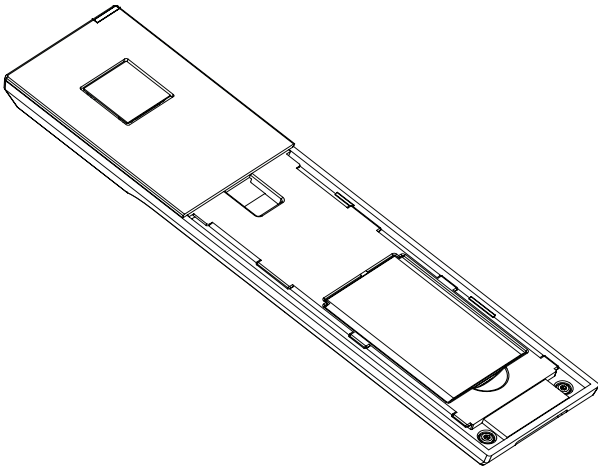

4. If you are replacing the battery: Place your thumb in the slot below the battery, and lift the battery out of the handset battery compartment
5. Place the top of the battery in the handset battery compartment so that the battery connectors are aligned.
6. Push the bottom of the battery down into the battery compartment.
7. Align all the tabs on the handset cover against the corresponding grooves on

the handset, then slide the handset cover closed.

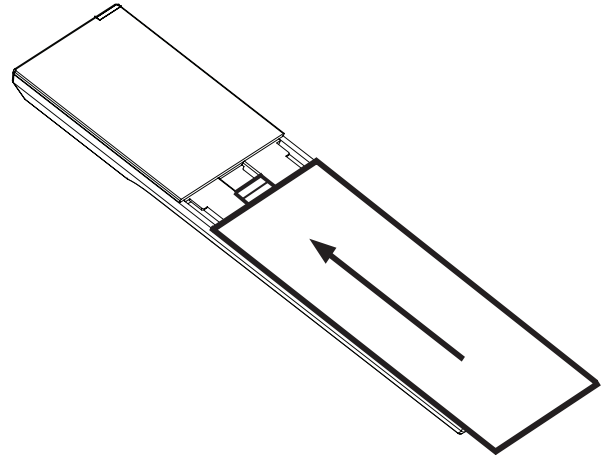

⚠ CAUTIONS

- There may be a risk of explosion if a wrong type of handset battery is used. Use only the supplied rechargeable battery or replacement battery (Model No. 523450AR1000). To order a replacement, contact authorized service personnel, your seller, or Snom.
- Dispose of used batteries according to the instructions.

INSTALLATION NOTES

⚠ CAUTION! Please be careful of sharp edges of base stand that can cause harm during the installation process.

Avoid placing the phone too close to:

- Communication devices such as television sets, DVD players, or other cordless telephones
- Excessive heat sources
- Noise sources such as a window with traffic outside, motors, microwave ovens, refrigerators, or fluorescent lighting
- Excessive dust sources such as a workshop or garage
- Excessive moisture
- Extremely low temperature
- Mechanical vibration or shock such as on top of a washing machine or work bench

HANDSET REGISTRATION

Place the cordless handset on the telephone base cradle. Handset registration happens automatically the first time a cordless handset is placed on the telephone base.

When the registration process completes, the **MESSAGE WAITING** LED flashes once and you hear 3 rising beeps as confirmation.

Each telephone base accommodates up to five cordless handsets. When you already have five registered handsets, you can replace one of them by a new handset if any one of the five registered handsets is disconnected from the base. For example, it is out of range, or its battery is removed or depleted. The previous registered handset is then deregistered from the telephone base.

HANDSET DEREGISTRATION

When a registered cordless handset is idle, press ***331734#**, then press **HOLD**. You will hear a confirmation tone when the deregistration process completes.

REGISTER A HANDSET TO ANOTHER TELEPHONE BASE

Any cordless 1-line handset can register to any cordless 1-line telephone base.

When a registered cordless handset is idle, place it on another telephone base. This cordless handset automatically registers to the new telephone base.

HANDSET BATTERY CHARGING

The battery must be fully charged before using the cordless handset for the first time. The **CHARGE** LED turns on when the cordless handset is charging on the telephone base. The battery is fully charged after 11 hours of continuous charging. For best performance, keep the cordless handset in the telephone base or charging base when not in use.

Installation

Cordless 1-line Handset and Charging base - HD3

INSTALL CHARGING BASE FOR DESKTOP

TO MOUNT THE CHARGING BASE ON THE BASE STAND

1. Align the grooves of the base stand with the charging base.
2. Slide the base stand up to secure it.

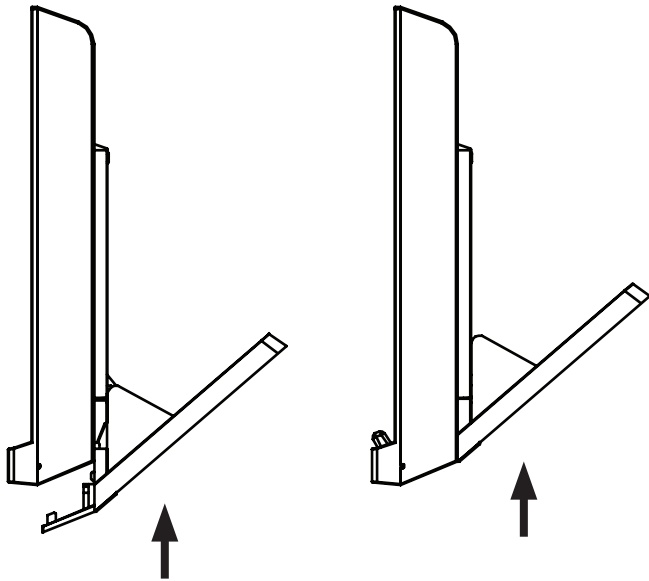

TO UNMOUNT THE BASE STAND

Simply slide the base stand down and lift it from the charging base.

CHARGING BASE INSTALLATION

The telephone comes ready for desktop use.

1. Install the charging base as shown below.
 - Make sure the power adapter is securely plugged into an outlet not controlled by a wall switch.

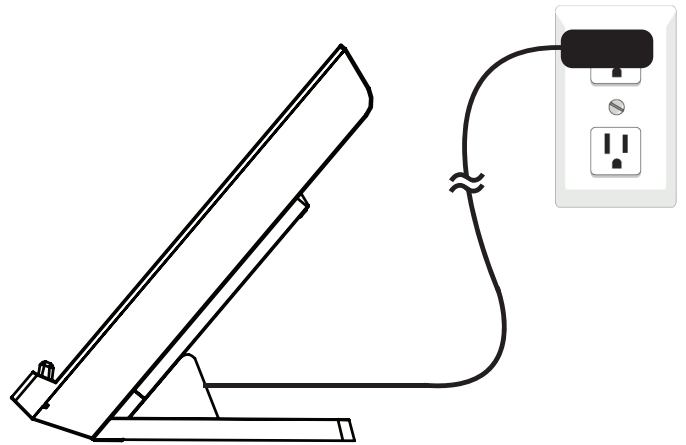

- The battery is fully charged after 11 hours of continuous charging. For best performance, keep the cordless handset in the charging base when not in use.

2. Press **[Mute]** on the handset. Listen for a dial tone, and then press **[Mute]** again to hang up.

⚠ CAUTIONS

Use only the supplied power adapter. The supplied power adapter is not designed for use in any other IT devices. Misusing it on your other IT devices shall be prohibited. To order a replacement, contact authorized service personnel, your seller, or Snom.

Set up

SIP Cordless 1-line Hotel Telephone - HD351

SIP Cordless 1-line Wi-Fi Enabled Hotel Telephone - HD351W

Default settings are indicated by asterisks (*).

SETTING	OPTIONS	ADJUSTABLE BY
Listening volume- Handset	1, 2, 3, 4*, 5, 6	User and administrator
Speakerphone volume - Handset	1, 2, 3, 4*, 5, 6	User and administrator
Speakerphone volume - telephone base	1, 2, 3, 4, 5*, 6, 7, 8, 9	User and administrator
Ringer volume - telephone base	1, 2, 3, 4, 5*, 6, 7, 8, 9	User and administrator
Ringer tone	Tone 1*, Tone 2, Tone 3	Administrator only

All telephone settings are programmed through the administrative web portal. Please refer to the SIP Phone Configuration Guide for details.

Voice Menu

The Voice menu enables you to use the handset to query and change telephone settings.

To access the Voice Menu:

1. When the telephone is idle, press this key sequence on the handset: **TALK * * ***
*.
A digitized voice on the handset will announce Voice Menu options.
2. Press the number key on the handset to select the desired menu option, or enter information.
A list of menu options is shown in the diagram below.
For example, to find out the IP address of the telephone, press **1** for Network Configuration, then press **2** for IP Address.
3. When you are finished with the Voice menu, press **OFF** on the handset or place it in the cradle.

NOTE: if you changed any network settings, your telephone will automatically reboot. This will enable your new settings to take effect.

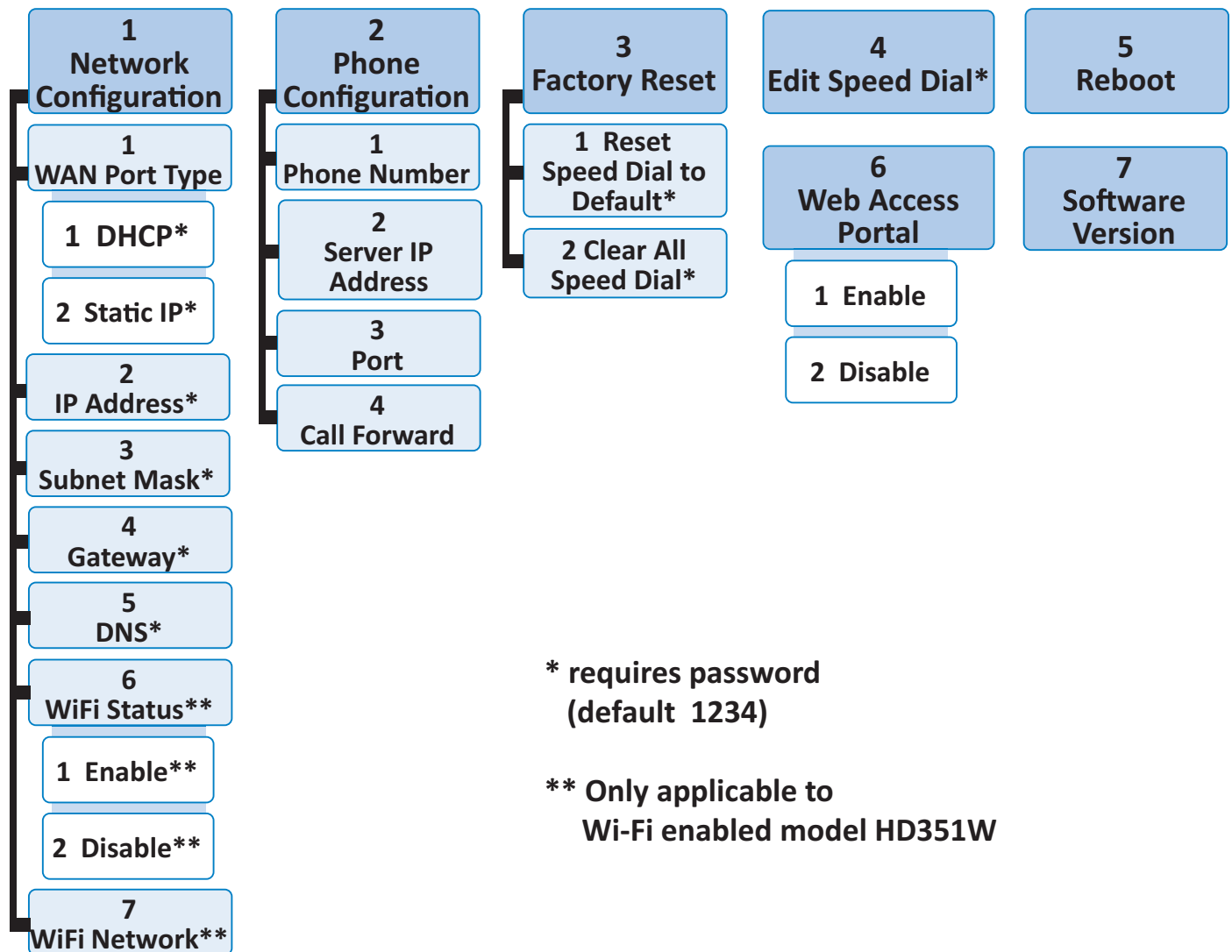

Operation

SIP Cordless 1-line Hotel Telephone - HD351

SIP Cordless 1-line Wi-Fi Enabled Hotel Telephone - HD351W

Cordless 1-line Handset and Charging base - HD3

USING THE CORDLESS HANDSET AND THE TELEPHONE BASE



The cordless handset and the telephone base speakerphone cannot be used at the same time on a call. However, calls can be switched between the cordless handset and the telephone base speakerphone.

RECEIVE A CALL

When there is an incoming call, the telephone rings and the message waiting LED flashes on the telephone base.



ANSWER A CALL USING THE CORDLESS HANDSET WHILE IT IS NOT ON THE TELEPHONE BASE OR CHARGING BASE

On the cordless handset, press  or .

- The  key illuminates when in use. The  key illuminates when in speakerphone mode.

ANSWER A CALL USING THE CORDLESS HANDSET WHILE IT IS CRADLED ON THE TELEPHONE BASE OR CHARGING BASE

Lift the cordless handset from the telephone base or charging base.

- The  key illuminates when in use. The  key illuminates when in speakerphone mode.



ANSWER A CALL USING THE TELEPHONE BASE



On the telephone base, press .

- The  key illuminates when in use.

PLACE A CALL

PLACE A CALL USING THE CORDLESS HANDSET

On the cordless handset, press  or . Listen for a dial tone and then dial the desired number, or press a Speed Dial key on the cordless handset to dial a programmed number.

- The  key illuminates when in use. The  key illuminates when in speakerphone mode.

PLACE A CALL USING THE TELEPHONE BASE

On the telephone base, press . Listen for a dial tone and then dial the desired number, or press a Speed Dial key on the telephone base to dial a programmed number.

- The  key illuminates when in use.

END A CALL



END A CALL WHEN USING THE CORDLESS HANDSET

Press  on the cordless handset or place it in the telephone base or charging base. The call ends when all handsets hang up.

END A CALL WHEN USING THE TELEPHONE BASE

Press .

SWITCH A CALL BETWEEN THE CORDLESS HANDSET AND THE TELEPHONE BASE SPEAKERPHONE

- To switch a call from the cordless handset to the telephone base speakerphone, press  on the telephone base.
- To switch a call from the telephone base speakerphone to the cordless handset which is not on the telephone base cradle, press  or  on the cordless handset.
- To switch a call from the telephone base speakerphone to the cordless handset which is cradled on the telephone base, lift the cordless handset from the telephone base.



SHARE A CALL

A maximum of two cordless handsets can be used at the same time on an external call.

JOIN A CALL

During a call, press  or  on another cordless handset to join.





HANDSET SPEAKERPHONE

During a call, press  on the cordless handset to switch between speakerphone mode and handset earpiece mode. The  key illuminates when in speakerphone mode.



VOLUME

Listening volume can be adjusted on the cordless handset and the telephone base.



ADJUST THE LISTENING VOLUME

- During a call on the handset, press  and  to adjust the listening volume. The next call returns to the default listening volume.
- During a call on the telephone base, press + and - to adjust the listening volume. The next call returns to the default listening volume.

ADJUST THE RINGER VOLUME OF THE TELEPHONE BASE

Ringer volume of the telephone base can be adjusted. When the telephone base is idle, press + and - to adjust the ringer volume.

CALL WAITING

1. When you hear a call waiting tone during a call, press  on the cordless handset to put the current call on hold and take the new incoming call.
2. Press  at any time to switch back and forth between calls.

MUTE

MUTE THE MICROPHONE

1. During a call, press **MUTE** / .

- The **MUTE** /  key on the handset / telephone base illuminates when the mute function is turned on. You can hear the party on the other end, but they cannot hear you.

2. Press **MUTE** /  again to resume the conversation.

- The light on the  key turns off.

MESSAGE WAITING INDICATOR

When a voice message is received, the message waiting LED on the telephone base flashes.

PLAY MESSAGES



Press **MESSAGE** /  in idle mode to play messages.

HOLD

TO PLACE A CALL ON HOLD:

During a call, press the **HOLD** /  key.

TO TAKE THE CALL OFF HOLD:

Press  or  on the handset, OR press  on the telephone base.

Appendix

Troubleshooting

If you have difficulty with the telephones, please try the suggestions below.

In case of malfunction, contact authorized service personnel, your seller, or Snom.

FOR CORDLESS TELEPHONE

QUESTION	SUGGESTIONS
1. The telephone does not work at all.	<ul style="list-style-type: none">• Make sure the Cat-5 network cable is plugged into the LAN port of the telephone base and the network wall jack with Power over Ethernet (PoE).• Make sure the battery is installed and charged correctly. For optimum daily performance, return the cordless handset to the telephone base, charging base or charging stand after use.• Unplug the Cat-5 network cable from the network wall jack. Wait for approximately 15 seconds, then plug it back in.• Charge the battery in the cordless handset for up to 16 hours.• If the battery is completely depleted, charge the battery for at least 30 minutes before use.• Remove the battery and then install it again. If that still does not work, it may be necessary to purchase a new battery.• Disconnect the telephone base from the network wall jack and connect a different working SIP telephone. If the other SIP telephone does not work, the problem is probably in the wiring or network server. Check your SIP server settings. Refer to the SIP Phone Configuration Guide for details.• Make sure the energy-saving charging mode is not activated. If this mode is activated, all telephone functions will be disabled, except battery charging.

2. There is no dial tone.

- Try all the above suggestions.
- The Cat-5 network cable may be defective. Install a new Cat-5 network cable.
- Make sure your network is providing Power over Ethernet (PoE).
- Disconnect the telephone base from the network wall jack and connect a different working SIP telephone. If there is no dial tone on this telephone either, the problem is in your wiring or network server. Check your SIP server settings and refer to the **SIP Phone Configuration Guide** for details.
- Make sure the initialization and system registration process completes. The speakerphone key blinks twice every second if there are errors with the initialization and system registration process. Check your SIP server settings. Refer to the **SIP Phone Configuration Guide** for details.
- Make sure the energy-saving charging mode is not activated. If this mode is activated, all telephone functions will be disabled, except battery charging.

3. I cannot dial out.

- Try all the above suggestions.
 - Make sure there is a dial tone before dialing. It is normal if the cordless handset takes a second or two to synchronize with the telephone base before producing a dial tone. Wait an extra second before dialing.
 - A prefix may be required for dialing some internal or external calls. Refer to the **SIP Phone Configuration Guide** for details.
 - Check your SIP server settings. If other SIP telephones in your hotel are having the same problem, the problem is in the wiring or network server. Contact your telephone service provider (charges may apply).
-

QUESTION	SUGGESTIONS
4. The Speed Dial key does not work at all.	<ul style="list-style-type: none"> The Speed Dial key may not be properly programmed. Refer to the SIP Phone Configuration Guide for details.
5. The telephone cannot register to the SIP network server.	<ul style="list-style-type: none"> Make sure your network is providing Power over Ethernet (PoE). Make sure the initialization and system registration process completes. If there is an error during the initialization and system registration process, the /SPEAKER key flashes twice every second. Disconnect the Cat-5 network cable from the network wall jack and connect it back into the network wall jack with Power over Ethernet (PoE) to start the initialization and system registration process again.
6. The LOW BATTERY LED illuminates on the cordless handset.	<ul style="list-style-type: none"> Place the cordless handset in the telephone base or charging base for recharging. Remove the battery and then install it again, and use it until fully depleted. Then charge the cordless handset in the telephone base or charging base for up to 16 hours. If the above measures do not correct the problem, replace the battery.
7. The battery does not charge in the cordless handset or the battery does not accept charge.	<ul style="list-style-type: none"> Make sure the cordless handset is placed in the telephone base or charging base correctly. The CHARGE LED should be on. Remove the battery and then install it again. Charge it for up to 16 hours. If the cordless handset is in the telephone base or charging base but the CHARGE LED is not on, refer to The CHARGE LED is off below. If the battery is completely depleted, charge the cordless handset for at least 30 minutes before use. If the above measures do not correct the problem, replace the battery.

QUESTION	SUGGESTIONS
<p>8. The CHARGE LED is off.</p>	<ul style="list-style-type: none"> • Clean the charging contacts on the cordless handset, telephone base, charging base and/or charging stand each month with a pencil eraser or a dry non-abrasive fabric. • Make sure the Cat-5 network cable is plugged in correctly and securely. • Unplug the Cat-5 network cable. Wait for 15 seconds before plugging it back in.
<p>9. The telephone does not ring when there is an incoming call.</p>	<ul style="list-style-type: none"> • Make sure the Cat-5 network cable is plugged into the LAN port of the telephone base and the network wall jack with Power over Ethernet (PoE). • The cordless handset may be too far from the telephone base. Move it closer to the telephone base. • Check your SIP server or telephone administrative settings. Refer to the SIP Phone Configuration Guide for details. • If other SIP telephones in your hotel are having the same problem, the problem is in the wiring or network server. Contact your telephone service provider (charges may apply). • Other electronic products such as HAM radios and other DECT phones can cause interference with your cordless phone. Try installing your phone as far away as possible from these types of electronic devices. • The Cat-5 network cable may be defective. Install a new Cat-5 network cable. • Remove the battery and then install it again. Then place the cordless handset in the telephone base. Wait for the handset to synchronize with the telephone base. Allow up to one minute for this to take place.

10. The cordless handset beeps and is not performing normally.

- Make sure the Cat-5 network cable is plugged into the **LAN** port of the telephone base and the network wall jack with Power over Ethernet (PoE).
- Check your SIP server or telephone administrative settings. Refer to the **SIP Phone Configuration Guide** for details.
- Disconnect the telephone base from the network wall jack and connect a different working SIP telephone. If the other SIP telephone has the same problem, the problem is in the wiring or network server. Contact your telephone service provider (charges may apply).
- Other electronic products such as HAM radios and other DECT phones can cause interference with your cordless phone. Try installing your phone as far away as possible from these types of electronic devices.

11. There is interference during a telephone conversation, or the call fades in and out when I am using the cordless handset.

- The cordless handset may be out of range. Move the handset closer to the telephone base or adjust the setting of RF transmission power. Refer **SIP Phone Configuration Guide** for details.
- Other electronic products such as HAM radios and other DECT phones can cause interference with your cordless phone. Try installing your phone as far away as possible from these types of electronic devices.
- If other SIP telephones in your hotel are having the same problem, the problem is in the wiring or network server. Contact your telephone service provider (charges may apply).

12. I hear other calls when using the telephone.

- Disconnect the telephone base from the network wall jack and connect a different working SIP telephone. Check your SIP server settings. If calls are still not clear, the problem is probably in the wiring or network server. Contact your telephone service provider (charges may apply).

QUESTION	SUGGESTIONS
13. I hear noise on the cordless handset and the keys do not work.	<ul style="list-style-type: none">• Make sure the Cat-5 network cable is plugged in correctly and securely.• Unplug the Cat-5 network cable. Wait for 15 seconds before plugging it back in.
14. Common cure for electronic equipment.	<ul style="list-style-type: none">• If the telephone is not responding normally, put the cordless handset in the telephone base. If it does not fix the problem, try the following (in the order listed):<ol style="list-style-type: none">A. Disconnect the power to the telephone base.B. Disconnect the battery on the cordless handset.C. Wait a few minutes before connecting power to the telephone base.D. Install the battery again and then place the cordless handset in the telephone base.E. Wait for the cordless handset to synchronize with the telephone base. Allow up to one minute for this to take place.

Maintenance

TAKING CARE OF YOUR TELEPHONE

Your telephone contains sophisticated electronic parts, so it must be treated with care.

AVOID ROUGH TREATMENT

Place the handset down gently. Save the original packing materials to protect your telephone if you ever need to ship it.

AVOID WATER

Your telephone can be damaged if it gets wet. Do not use the handset outdoors in the rain, or handle it with wet hands. Do not install the telephone base near a sink, bathtub or shower.

ELECTRICAL STORMS

Electrical storms can sometimes cause power surges harmful to electronic equipment. For your own safety, take caution when using electrical appliances during storms.

CLEANING YOUR TELEPHONE

Your telephone has a durable plastic casing that should retain its luster for many years. Clean it only with a soft cloth slightly dampened with water or mild soap. Do not use excess water or cleaning solvents of any kind.

Remember that electrical appliances can cause serious injury if used when you are wet or standing in the water. If the telephone base should fall into the water, **DO NOT RETRIEVE IT UNTIL YOU UNPLUG THE NETWORK CABLE FROM THE WALL.** Then remove the telephone by the unplugged cords.

Disclaimer and Limitation of Liability

Snom Technology GmbH and its suppliers assume no responsibility for any damage or loss resulting from the use of this user's manual. Snom Technology GmbH and its suppliers assume no responsibility for any loss or claims by third parties that may arise through the use of this product. Snom Technology GmbH and its suppliers assume no responsibility for any damage or loss caused by deletion of data as a result of malfunction, or repairs. Be sure to make backup copies of important data on other media to protect against data loss.

REMEMBER THAT ELECTRICAL APPLIANCES CAN CAUSE SERIOUS INJURY IF USED WHEN YOU ARE WET OR STANDING IN WATER. IF THE TELEPHONE BASE SHOULD FALL INTO WATER, DO NOT RETRIEVE IT UNTIL YOU UNPLUG THE POWER CORD AND/OR ETHERNET CABLE FROM THE WALL. THEN REMOVE THE TELEPHONE BY THE UNPLUGGED CORDS.

European Directives

This equipment is compliant with 2014/53/EU (RED) and 2011/65/EU (ROHS).

Declaration of Conformity

The declaration of conformity can be downloaded at www.snom.com/conformity.



Disposal of batteries and product

These symbols (①, ②) on the products, packaging, and/or accompanying documents mean that used electrical and electronic products and batteries must not be mixed with general household waste.

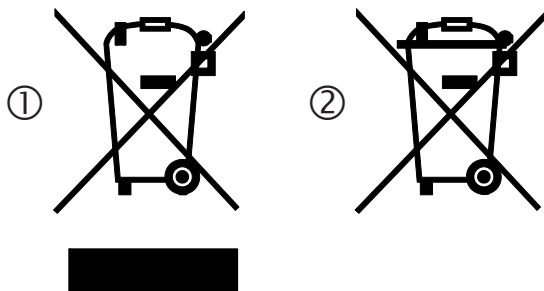

For proper treatment, recovery and recycling of old products and batteries, please take them to applicable collection points in accordance with your national legislation.

By disposing of them correctly, you will help to save valuable resources and prevent any potential negative effects on human health and the environment.

For more information about collection and recycling, please contact your local municipality. Penalties may be applicable for incorrect disposal of this waste, in accordance with national legislation.

PRODUCT DISPOSAL INSTRUCTIONS FOR BUSINESS USERS

If you wish to discard electrical and electronic equipment, please contact your dealer or supplier for further information.

INFORMATION ON DISPOSAL IN OTHER COUNTRIES OUTSIDE THE EUROPEAN UNION

These symbols (①, ②) are only valid in the European Union. If you wish to discard these items, please contact your local authorities or dealer and ask for the correct method of disposal.

NOTE FOR THE BATTERY SYMBOL

This symbol (②) might be used in combination with a chemical symbol. In this case it complies with the requirement set by the Directive for the chemical involved.



snom

Specifications are subject to change without notice.
Copyright © 2023
Snom Technology GmbH
All rights reserved. 11/23.
HD351_HD351W_HD3_UM_V1_CEC_EU-UK_14NOV2023